

CMH

CMJ and CMT also available



CSH

CSJ and CST also available



COH

COT also available

ControlHoist™

Commercial Operators

ControlHoist Basic

The ControlHoist Basic is a belt-drive, ½ hp, limited-duty commercial operator.

Designed to operate at 14 cycles/hour, the ControlHoist Basic is perfect for low cycle or lighter door applications with budget in mind.

ControlHoist Standard

The ControlHoist Standard model opens the offering to 30 cycles/hour performance.

Available with ⅓, ½, and ¾ hp options, the continuous-duty motor on this belt-drive operator is ideal for more demanding environments and door applications.

ControlHoist Optima

The ControlHoist Optima is the continuous-duty, gear-driven, “Go anywhere” powerhouse of the Raynor commercial operator offering.

Available from ½ hp up to 2 hp, The Optima is designed for high cycles in robust environments and can handle our largest doors.

ControlHoist™ Basic

Basic Commercial Operator

The ControlHoist Basic is a ½ horsepower, belt-drive operator, perfect for operating smaller sized sectional doors, rolling doors and grilles. This entry level unit is loaded with innovative features along with a durable construction suitable for most commercial applications.

Models

The **CMJ** (Jackshaft) model is designed for use on vertical lift and lift clearance sectional doors or small rolling doors and grilles. The operator can be wall or hood mounted on either side of the door. It incorporates a floor level disconnect mechanism for manual operation.

The **CMH** (Jackshaft with Hoist) model is designed for use on vertical lift and lift clearance sectional doors or small rolling doors and grilles. The operator can be wall or hood mounted on either side of the door. It incorporates the patented Hoist-a-matic®, a self-engaging chain hoist for manual operation, which simplifies operation and installation.

The **CMT** (Trolley) model is designed for use on smaller and low-cycling industrial standard lift sectional doors. It features a high starting torque limited-duty industrial type motor and a quick release disconnect arm.

Specifications

Operation: Jackshaft (optional Hoist)
Trolley

Duty Cycle: 14/hr or 50 cycles/day

Drive: Belt

NEMA Options: NEMA 1

Motor: ½ HP, 120V single phase, 60Hz limited-duty motor with 1.5s delay on reverse and internal automatic reset thermal overload protection.

Circuit Board: Solid State Logic with diagnostic LEDs

Power: 120V Single-Phase

Radio Receiver: Optional

Radio Transmitter: Optional

Warranty: 3 years with purchase of door
2 years with purchase of operator only

Raynor Advantage: Easily configure the correct operator with a door for a total Raynor branded system with an extended extra year of warranty.



CMJ

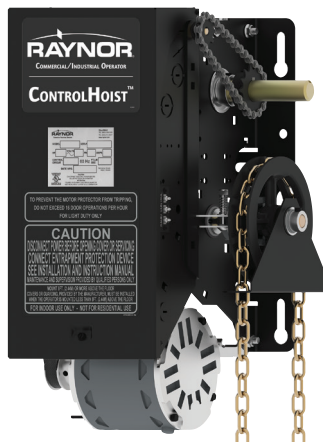

CMH

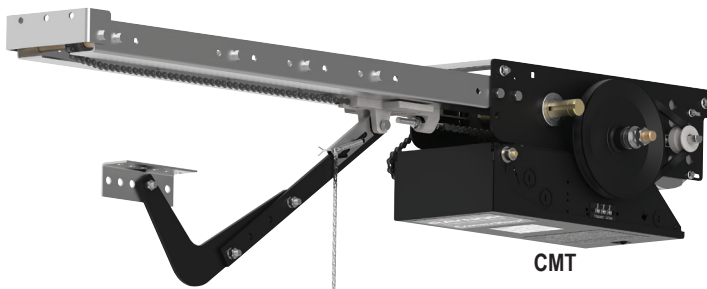

CMT

ControlHoist Basic

Standard Features

Manual Operation:

CMJ- A floor level disconnect mechanism which must be engaged for manual push-up operation.

CMH- Hoist-a-matic® self-engaging hoist (floor level engagement device is not required to operate) for manual chain operation. An electrical interlock automatically disconnects power to the motor operator when the chain hoist is engaged. Hoist on right is standard.

CMT- Quick release disconnect arm for manual push-up operation.

Mechanical Brake: Built-in mechanical brake system helps to prevent the door from drifting and adds security by preventing forced opening.

Drive Reduction: Primary reduction is belt drive. Secondary reduction is by chain and sprocket.

Adjustable Friction Clutch: Helps to protect the door and operator from damage should it come into contact with any obstruction.

Corrosion Protection: Frame and control enclosure protected by baked on, long lasting enamel finish. All shafts protected by yellow chromate coating.

Accu-cam® Limit Feature: For precise and quick one-handed limit setting adjustments.

Cycle Counter: LED indicates the number of cycles logged for easy maintenance support.

Programmable Mid-Stop: This feature enables partial opening of door to a preprogrammed position for energy savings, time savings and convenience.

Timer-To-Close: Closes the door automatically after a predetermined amount of time has elapsed, for security and convenience.

Exterior Radio Control Terminal: Provides for fast and easy connection of radio controls. When range is an issue, an external mounted radio receiver allows the flexibility for the receiver to be moved to a new location for improved range.

3-Button Control Station: This station provides open/close/stop functions.

Controls

Entrapment: UL 325 2010 requires all commercial operators to use constant pressure to close or be equipped with an approved monitored entrapment protection device, such as a monitored photo eye or reversing edge. All ControlHoist commercial operators are provided standard with constant pressure to close. In addition, a non-monitored entrapment device can also be selected.

Circuit Board: 24VDC relaying circuit with a 40VA class II transformer, non-volatile memory. Features available:

- 1.5s delay on reverse
- Maximum run timer
- Mid-stop
- Timer to close
- Advance close system
- Test buttons
- Reverse wiring detection
- Door lock sensor

Certifications: ANSI/CAN/UL325 and CSA C22.2-247.92.

CMT Dimensions

Maximum Door Height:

14' (4267 mm)

Headroom for Tracks:

5" (127 mm) above the highest point of door travel

Back Room Door Height:

+ 3'11" (1194 mm)

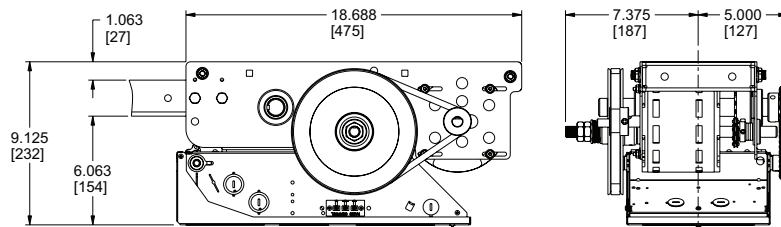

CMJ & CMH Dimensions

Maximum Door Height:

14' (4267 mm)

Clearance:

Side room required 15" (381 mm)

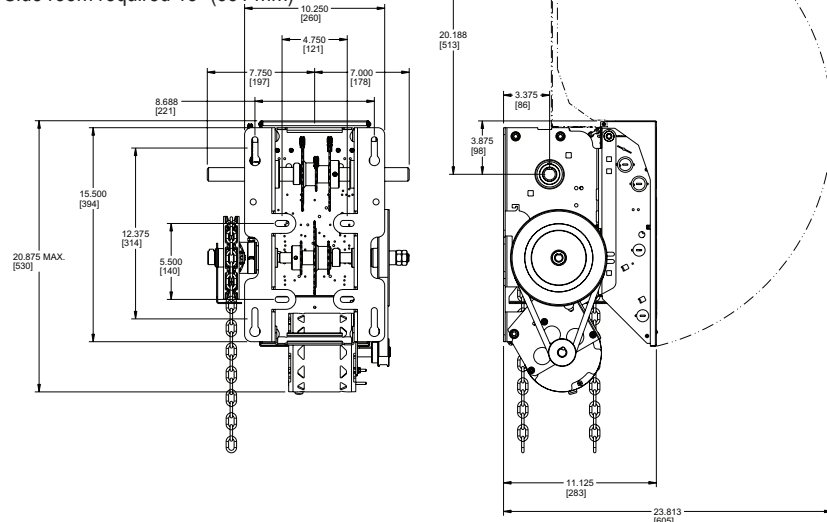

ControlHoist™ Standard

Standard Commercial Operator

The ControlHoist Standard is a medium-duty, belt-drive operator, designed for high cycle applications and use on standard to larger size sectional doors, rolling door and grilles. Innovative features, along with durable mechanical design, offer a consistent and reliable performance day in and day out.



Specifications

- Operation:** Trolley
Dual Trolley
Jackshaft with or without Hoist
- Duty Cycle:** 30/hr, 300/day
- Drive:** Belt
- NEMA Options:** NEMA 1, NEMA 7 & 9
- Motor:** Continuous Duty — 1/8, 1/2, 3/4 HP
- Circuit Board:** Solid State Logic with LCD Display
- Power:** 120/240V Single-Phase
208/240/480/575V 3-Phase
- Brake:** Standard on jackshaft & 3/4 hp trolley models
Optional on 1/8 & 1/2 HP trolley models
- Wiring Options:** 24V Class 2, On-board Selection
- Radio Receiver:** Optional
- Radio Transmitter:** Optional
- Warranty:** 3 years with purchase of door
2 years with purchase of operator only
- Raynor Advantage:** Easily configure the correct operator with a door for a total Raynor branded system with an extended extra year of warranty.

CSJ and CST also available

ControlHoist™ Optima



COH

Optima Commercial Operator

Designed for larger sectional doors, rolling doors and higher-cycle applications, the ControlHoist Optima is a heavy-duty, gear driven operator that is built with a continuous-duty, overload protected motor with high starting torque. All units feature heavy-duty industrial ball bearings, worm gear drive in oil bath and an electromechanical brake. Innovative features along with durable mechanical design, provide consistent and reliable operation for the most stringent applications.

Specifications

- Operation:** Trolley
Dual Trolley
Jackshaft with Hoist
- Duty Cycle:** 30/hr, 300/day
- Drive:** Gear
- NEMA Options:** NEMA 1, NEMA 4, NEMA 7 & 9
- Motor:** Continuous Duty — ½, ¾, 1, 1½, 2 HP
- Circuit Board:** Solid State Logic with LCD Display
- Power:** 120/240V Single-Phase
208/240/480/575V 3-Phase
- Brake:** Standard on all jackshaft & trolley models
- Wiring Options:** 24V Class 2, On-board Selection
- Radio Receiver:** Optional
- Radio Transmitter:** Optional
- Warranty:** 3 years with purchase of door
2 years with purchase of operator only
- Raynor Advantage:** Easily configure the correct operator with a door for a total Raynor branded system with an extended extra year of warranty.

**For NEMA 4 & 575V 3-Phase specifications, please contact factory.*

COT also available

ControlHoist Standard & Optima

Standard Features

Entrapment: UL 325 2010 requires all commercial operators to use constant pressure to close or be equipped with an approved monitored entrapment protection device, such as a monitored photo eye or reversing edge. All ControlHoist Standard & Optima operators are provided standard with constant pressure to close. Up to two (2) monitored entrapment devices can be selected. In addition, up to two (2) non-monitored entrapment devices can also be selected.

LCD (Liquid Crystal Display): The 16 character LCD display allows for easy programming with an intuitive set up menu. Status indicators provide real-time status and display error messages for easy troubleshooting assistance.

Cycle Counter: LCD clearly indicates the exact number of cycles logged for easy maintenance support.

Programmable Mid-Stop: Adjustable from 3-30 seconds, this feature enables partial opening of door to a preprogrammed position for energy savings, time savings and convenience.

Timer-To-Close: Closes the door automatically after a predetermined amount of time has elapsed, for security and convenience.

Ventilation Feature: When a device such as a CO detector is activated, the door will partially open for a pre-determined amount of time. Once the CO detector is clear, the door will close.

Fire Station Timer: Ideal for fire stations. A push button or pull cord can be used to activate the open cycle and timer to close feature. Only the push button or pull cord will control the timer to close.

Motor: Continuous-duty, overload protected motor with high starting torque.

Drive Reduction:

Optima- Primary reduction by worm gear in oil bath. Secondary reduction by chain and sprocket.
Standard- Primary reduction belt drive. Secondary reduction is by chain and sprocket.

Electro Magnetic Brake System: 24VDC brake. Fewer mechanical parts for improved reliability. (Brake comes standard on all Optima and Standard models except for the 1/3 and 1/2 HP CST models, they are optional)

Adjustable Friction Clutch: Helps to protect the door and operator from damage should it come into contact with any obstruction.

3-Button Control Station: Provides open/close/stop functions.

Exterior Radio Control Terminal: Provides for fast and easy connection of radio controls. When range is an issue, an optional external mounted radio receiver allows the flexibility for the receiver to be moved to a new location for improved range.

Optional Feature

Auxiliary Contact Board: Provides auxiliary contacts when the door is in motion and at the open and close limits. The auxiliary board provides but is not limited to the following features:

- Courtesy Light which illuminates whenever the door is activated
- Capability to tie into Horn & Strobes for ADA compliance
- Capability to tie into a Traffic Light to provide safe entering and exiting of the facility
- Ability to connect to a facilities alarm or security system

Circuit Board

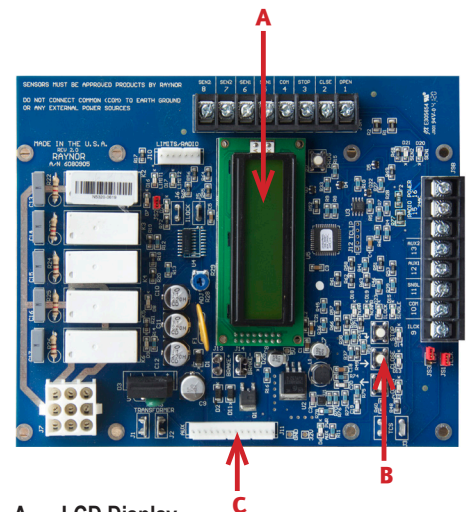

- A. LCD Display
- B. On-board 3-button open/close/stop
- C. Auxiliary Board Harness

Exclusively Distributed by:

